

### FEATURES

**Bandwidth >400 MHz**  
**Low Insertion Loss and On Resistance: 2.2  $\Omega$  Typical**  
**On-Resistance Flatness 0.3  $\Omega$  Typical**  
**Single 3 V/5 V Supply Operation**  
**Very Low Distortion: <0.3%**  
**Low Quiescent Supply Current (1 nA Typical)**  
**Fast Switching Times**  
 $t_{ON}$  6 ns  
 $t_{OFF}$  3 ns  
**TTL/CMOS Compatible**

### FUNCTIONAL BLOCK DIAGRAM

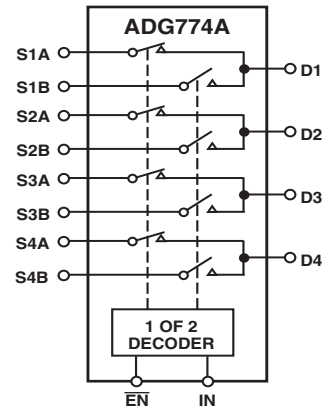

### GENERAL DESCRIPTION

The ADG774A is a monolithic CMOS device comprising four 2:1 multiplexer/demultiplexers with high impedance outputs. The CMOS process provides low power dissipation yet gives high switching speed and low on resistance. The on-resistance variation is typically less than 0.5  $\Omega$  over the input signal range.

The bandwidth of the ADG774A is typically 400 MHz and this, coupled with low distortion (typically 0.3%), makes the part suitable for switching of high-speed data signals.

The on-resistance profile is very flat over the full analog input range ensuring excellent linearity and low distortion. CMOS construction ensures ultralow power dissipation.

The ADG774A operates from a single 3.3 V/5 V supply and is TTL logic compatible. The control logic for each switch is shown in the Truth Table.

These switches conduct equally well in both directions when ON. In the OFF condition, signal levels up to the supplies are blocked. The ADG774A switches exhibit break-before-make switching action.

### PRODUCT HIGHLIGHTS

1. Wide bandwidth data rates >400 MHz.
2. Ultralow Power Dissipation.
3. Low leakage over temperature.
4. Break-Before-Make Switching.  
This prevents channel shorting when the switches are configured as a multiplexer.
5. Crosstalk is typically -70 dB @ 10 MHz.
6. Off isolation is typically -65 dB @ 10 MHz.

### REV. A

Information furnished by Analog Devices is believed to be accurate and reliable. However, no responsibility is assumed by Analog Devices for its use, nor for any infringements of patents or other rights of third parties that may result from its use. No license is granted by implication or otherwise under any patent or patent rights of Analog Devices. Trademarks and registered trademarks are the property of their respective companies.

# ADG774A—SPECIFICATIONS

**SINGLE SUPPLY**<sup>1</sup> ( $V_{DD} = 5\text{ V} \pm 10\%$ ,  $GND = 0\text{ V}$ . All specifications  $T_{MIN}$  to  $T_{MAX}$  unless otherwise noted.)

Parameter	B Version		Unit	Test Conditions/Comments
	25°C	$T_{MIN}$ to $T_{MAX}$		
<b>ANALOG SWITCH</b>				
Analog Signal Range		0 to 2.5	V	
On Resistance ( $R_{ON}$ )	2.2		$\Omega$ typ	$V_D = 0\text{ V}$ to $1\text{ V}$ ; $I_S = -10\text{ mA}$
	3.5	4	$\Omega$ max	
On Resistance Match Between Channels ( $\Delta R_{ON}$ )	0.15		$\Omega$ typ	$V_D = 0\text{ V}$ to $1\text{ V}$ ; $I_S = -10\text{ mA}$
		0.5	$\Omega$ max	
On Resistance Flatness ( $R_{FLAT(ON)}$ )	0.3		$\Omega$ typ	$V_D = 0\text{ V}$ to $1\text{ V}$ ; $I_S = -10\text{ mA}$
		0.6	$\Omega$ max	
<b>LEAKAGE CURRENTS</b>				
Source OFF Leakage $I_S$ (OFF)	$\pm 0.001$		nA typ	$V_D = 3\text{ V}$ , $V_S = 1\text{ V}$ ; $V_D = 1\text{ V}$ , $V_S = 3\text{ V}$ ; Test Circuit 2
	$\pm 0.1$	$\pm 0.25$	nA max	
Drain OFF Leakage $I_D$ (OFF)	$\pm 0.001$		nA typ	$V_D = 3\text{ V}$ , $V_S = 1\text{ V}$ ; $V_D = 1\text{ V}$ , $V_S = 3\text{ V}$ ; Test Circuit 2
	$\pm 0.1$	$\pm 0.25$	nA max	
Channel ON Leakage $I_D$ , $I_S$ (ON)	$\pm 0.001$		nA typ	$V_D = V_S = 3\text{ V}$ ; $V_D = V_S = 1\text{ V}$ ; Test Circuit 3
	$\pm 0.1$	$\pm 0.25$	nA max	
<b>DIGITAL INPUTS</b>				
Input High Voltage, $V_{INH}$		2.4	V min	$V_{IN} = V_{INL}$ or $V_{INH}$
Input Low Voltage, $V_{INL}$		0.8	V max	
Input Current				
$I_{INL}$ or $I_{INH}$	0.001		$\mu\text{A}$ typ	
		$\pm 0.1$	$\mu\text{A}$ max	
$C_{IN}$ , Digital Input Capacitance		3	pF typ	
<b>DYNAMIC CHARACTERISTICS</b> <sup>2</sup>				
$t_{ON}$ , $t_{ON}(\overline{EN})$		6	ns typ	$C_L = 35\text{ pF}$ , $R_L = 50\ \Omega$ ; $V_S = 2\text{ V}$ ; Test Circuit 4
		12	ns max	
$t_{OFF}$ , $t_{OFF}(\overline{EN})$		3	ns typ	$C_L = 35\text{ pF}$ , $R_L = 50\ \Omega$ ; $V_S = 2\text{ V}$ ; Test Circuit 4
		6	ns max	
Break-Before-Make Time Delay, $t_D$		3	ns typ	$C_L = 35\text{ pF}$ , $R_L = 50\ \Omega$ ; $V_{S1} = V_{S2} = 2\text{ V}$ ; Test Circuit 5
		1	ns min	
Off Isolation		-65	dB typ	$f = 10\text{ MHz}$ ; $R_L = 50\ \Omega$ ; Test Circuit 7
Channel-to-Channel Crosstalk		-70	dB typ	
Bandwidth -3 dB		400	MHz typ	Test Circuit 6, $R_L = 50\ \Omega$ ; $R_L = 100\ \Omega$
Distortion		0.3	% typ	
Charge Injection		6	pC typ	$C_L = 1\text{ nF}$ ; Test Circuit 9, $V_S = 0\text{ V}$
$C_S$ (OFF)		5	pF typ	
$C_D$ (OFF)		7.5	pF typ	
$C_D$ , $C_S$ (ON)		12	pF typ	
<b>POWER REQUIREMENTS</b>				
$I_{DD}$		1	$\mu\text{A}$ max	$V_{DD} = 5.5\text{ V}$ Digital Inputs = $0\text{ V}$ or $V_{DD}$
	0.001		$\mu\text{A}$ typ	

## NOTES

<sup>1</sup>Temperature ranges are as follows: B Version,  $-40^\circ\text{C}$  to  $+85^\circ\text{C}$ .

<sup>2</sup>Guaranteed by design, not subject to production test.

Specifications subject to change without notice.

**SINGLE SUPPLY<sup>1</sup>** ( $V_{DD} = 3\text{ V} \pm 10\%$ ,  $GND = 0\text{ V}$ . All specifications  $T_{MIN}$  to  $T_{MAX}$  unless otherwise noted.)

Parameter	B Version $T_{MIN}$ to $T_{MAX}$		Unit	Test Conditions/Comments
	25°C			
<b>ANALOG SWITCH</b>				
Analog Signal Range		0 to 1.5	V	
On Resistance ( $R_{ON}$ )	4		$\Omega$ typ	$V_D = 0\text{ V}$ to $1\text{ V}$ ; $I_S = -10\text{ mA}$
	6	7	$\Omega$ max	
On Resistance Match Between Channels ( $\Delta R_{ON}$ )	0.15		$\Omega$ typ	$V_D = 0\text{ V}$ to $1\text{ V}$ ; $I_S = -10\text{ mA}$
		0.5	$\Omega$ max	
On Resistance Flatness ( $R_{FLAT(ON)}$ )	1.5		$\Omega$ typ	$V_D = 0\text{ V}$ to $1\text{ V}$ ; $I_S = -10\text{ mA}$
		3	$\Omega$ max	
<b>LEAKAGE CURRENTS</b>				
Source OFF Leakage $I_S$ (OFF)	$\pm 0.001$		nA typ	$V_D = 2\text{ V}$ , $V_S = 1\text{ V}$ ; $V_D = 1\text{ V}$ , $V_S = 2\text{ V}$ ; Test Circuit 2
	$\pm 0.1$	$\pm 0.25$	nA max	
Drain OFF Leakage $I_D$ (OFF)	$\pm 0.001$		nA typ	$V_D = 2\text{ V}$ , $V_S = 1\text{ V}$ ; $V_D = 1\text{ V}$ , $V_S = 2\text{ V}$ ; Test Circuit 2
	$\pm 0.1$	$\pm 0.25$	nA max	
Channel ON Leakage $I_D$ , $I_S$ (ON)	$\pm 0.001$		nA typ	$V_D = V_S = 2\text{ V}$ ; $V_D = V_S = 1\text{ V}$ ; Test Circuit 3
	$\pm 0.1$	$\pm 0.25$	nA max	
<b>DIGITAL INPUTS</b>				
Input High Voltage, $V_{INH}$		2.0	V min	
Input Low Voltage, $V_{INL}$		0.4	V max	
Input Current $I_{INL}$ or $I_{INH}$	0.001		$\mu\text{A}$ typ	$V_{IN} = V_{INL}$ or $V_{INH}$
		$\pm 0.1$	$\mu\text{A}$ max	
$C_{IN}$ , Digital Input Capacitance		3	pF typ	
<b>DYNAMIC CHARACTERISTICS<sup>2</sup></b>				
$t_{ON}$ , $t_{ON}$ ( $\overline{EN}$ )		7	ns typ	$C_L = 35\text{ pF}$ , $R_L = 50\ \Omega$ ; $V_S = 1.5\text{ V}$ ; Test Circuit 4
		14	ns max	
$t_{OFF}$ , $t_{OFF}$ ( $\overline{EN}$ )		4	ns typ	$C_L = 35\text{ pF}$ , $R_L = 50\ \Omega$ ; $V_S = 1.5\text{ V}$ ; Test Circuit 4
		8	ns max	
Break-Before-Make Time Delay, $t_D$		3	ns typ	$C_L = 35\text{ pF}$ , $R_L = 50\ \Omega$ ; $V_{S1} = V_{S2} = 1.5\text{ V}$ ; Test Circuit 5
		1	ns min	
Off Isolation		-65	dB typ	$f = 10\text{ MHz}$ ; $R_L = 50\ \Omega$ , Test Circuit 7
Channel-to-Channel Crosstalk		-70	dB typ	$f = 10\text{ MHz}$ ; $R_L = 50\ \Omega$ , Test Circuit 8
Bandwidth -3 dB		400	MHz typ	Test Circuit 6; $R_L = 50\ \Omega$
Distortion		1.5	% typ	$R_L = 100\ \Omega$
Charge Injection		4	pC typ	$C_L = 1\text{ nF}$ ; Test Circuit 9, $V_S = 0\text{ V}$
$C_S$ (OFF)		5	pF typ	
$C_D$ (OFF)		7.5	pF typ	
$C_D$ , $C_S$ (ON)		12	pF typ	
<b>POWER REQUIREMENTS</b>				
$I_{DD}$	0.001	1	$\mu\text{A}$ max $\mu\text{A}$ typ	$V_{DD} = 3.3\text{ V}$ Digital Inputs = $0\text{ V}$ or $V_{DD}$

## NOTES

<sup>1</sup>Temperature ranges are as follows: B Version,  $-40^\circ\text{C}$  to  $+85^\circ\text{C}$ .<sup>2</sup>Guaranteed by design, not subject to production test.

Specifications subject to change without notice.

Table I. Truth Table

$\overline{EN}$	IN	D1	D2	D3	D4	Function
1	X	Hi-Z	Hi-Z	Hi-Z	Hi-Z	DISABLE
0	0	S1A	S2A	S3A	S4A	IN = 0
0	1	S1B	S2B	S3B	S4B	IN = 1

# ADG774A

## ABSOLUTE MAXIMUM RATINGS<sup>1</sup>

(T<sub>A</sub> = 25°C unless otherwise noted)

V <sub>DD</sub> to GND	−0.3 V to +6 V
Analog, Digital Inputs <sup>2</sup>	−0.3 V to V <sub>DD</sub> + 0.3 V or 30 mA, Whichever Occurs First
Continuous Current, S or D	100 mA
Peak Current, S or D	300 mA (Pulsed at 1 ms, 10% Duty Cycle max)
Operating Temperature Range	
Industrial (B Version)	−40°C to +85°C
Storage Temperature Range	−65°C to +150°C
Junction Temperature	150°C
QSOP Package, Power Dissipation	566 mW
θ <sub>JA</sub> Thermal Impedance	149.97°C/W
Lead Temperature, Soldering	
Vapor Phase (60 sec)	215°C
Infrared (15 sec)	220°C

## NOTES

<sup>1</sup> Stresses above those listed under Absolute Maximum Ratings may cause permanent damage to the device. This is a stress rating only; functional operation of the device at these or any other conditions above those listed in the operational sections of this specification is not implied. Exposure to absolute maximum rating conditions for extended periods may affect device reliability. Only one absolute maximum rating may be applied at any one time.

<sup>2</sup> Overvoltages at IN, S or D will be clamped by internal diodes. Current should be limited to the maximum ratings given.

## PIN CONFIGURATION (QSOP)

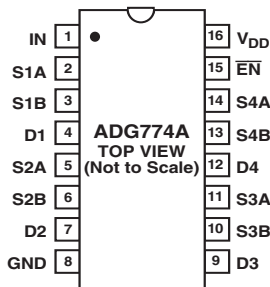

## TERMINOLOGY

V <sub>DD</sub>	Most Positive Power Supply Potential.
GND	Ground (0 V) Reference.
S	Source Terminal. May be an input or output.
D	Drain Terminal. May be an input or output.
IN	Logic Control Input.
$\overline{\text{EN}}$	Logic Control Input.
R <sub>ON</sub>	Ohmic resistance between D and S.
ΔR <sub>ON</sub>	On Resistance match between any two channels i.e., R <sub>ON</sub> max – R <sub>ON</sub> min.
R <sub>FLAT(ON)</sub>	Flatness is defined as the difference between the maximum and minimum value of on resistance as measured over the specified analog signal range.
I <sub>S</sub> (OFF)	Source Leakage Current with the switch “OFF.”
I <sub>D</sub> (OFF)	Drain Leakage Current with the switch “OFF.”
I <sub>D</sub> , I <sub>S</sub> (ON)	Channel Leakage Current with the switch “ON.”
V <sub>D</sub> (V <sub>S</sub> )	Analog Voltage on Terminals D, S.
C <sub>S</sub> (OFF)	“OFF” Switch Source Capacitance.
C <sub>D</sub> (OFF)	“OFF” Switch Drain Capacitance.
C <sub>D</sub> , C <sub>S</sub> (ON)	“ON” Switch Capacitance.
t <sub>ON</sub>	Delay between applying the digital control input and the output switching on. See Test Circuit 4.
t <sub>OFF</sub>	Delay between applying the digital control input and the output switching Off.
t <sub>D</sub>	“OFF” time or “ON” time measured between the 90% points of both switches, when switching from one address state to another. See Test Circuit 5.
Crosstalk	A measure of unwanted signal that is coupled through from one channel to another as a result of parasitic capacitance.
Off Isolation	A measure of unwanted signal coupling through an “OFF” switch.
Bandwidth	Frequency response of the switch in the ON state measured at 3 dB down.
Distortion	R <sub>FLAT(ON)</sub> /R <sub>L</sub>

## ORDERING GUIDE

Model	Temperature Range	Package Descriptions	Package Options
ADG774ABRQ	−40°C to +85°C	RQ = 0.15" Shrink Small Outline Package (QSOP)	RQ-16

## CAUTION

ESD (electrostatic discharge) sensitive device. Electrostatic charges as high as 4000 V readily accumulate on the human body and test equipment and can discharge without detection. Although the ADG774A features proprietary ESD protection circuitry, permanent damage may occur on devices subjected to high energy electrostatic discharges. Therefore, proper ESD precautions are recommended to avoid performance degradation or loss of functionality.



# Typical Performance Characteristics—ADG774A

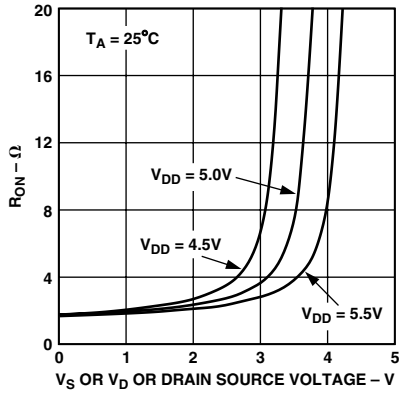

TPC 1. On Resistance as a Function of  $V_D$  ( $V_S$ ) for Various Single Supplies

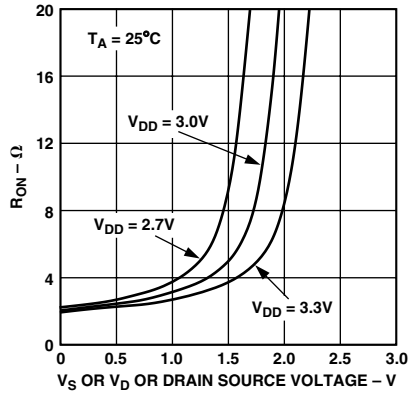

TPC 2. On Resistance as a Function of  $V_D$  ( $V_S$ ) for Various Single Supplies

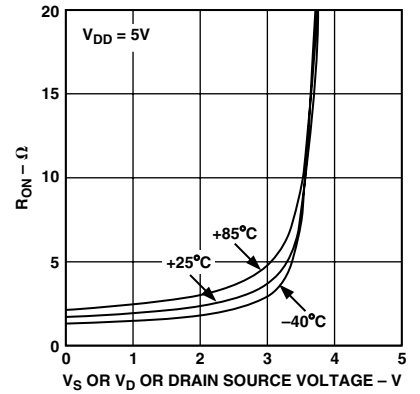

TPC 3. On Resistance as a Function of  $V_D$  ( $V_S$ ) for Different Temperatures with 5 V Single Supplies

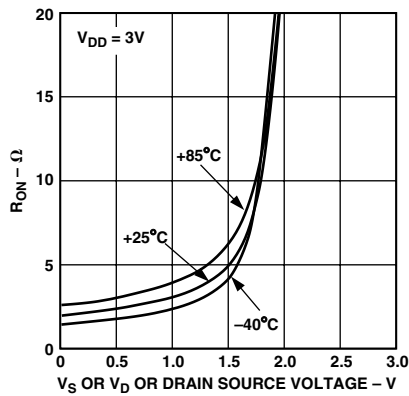

TPC 4. On Resistance as a Function of  $V_D$  ( $V_S$ ) for Different Temperatures with 3 V Single Supplies

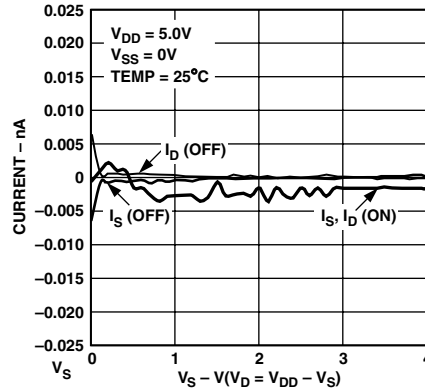

TPC 5. Leakage Current as a Function of  $V_D$  ( $V_S$ )

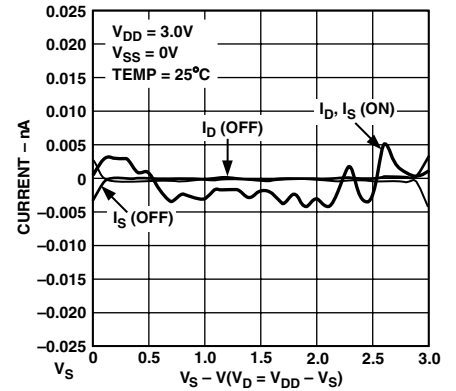

TPC 6. Leakage Current as a Function of  $V_D$  ( $V_S$ )

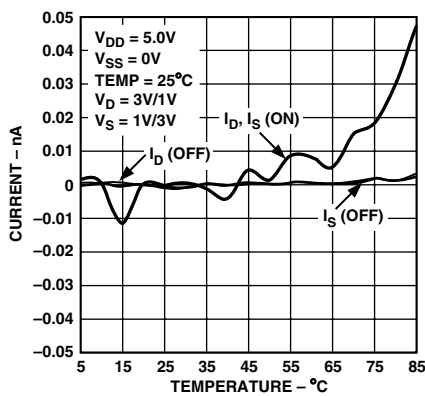

TPC 7. Leakage Current as a Function of Temperature

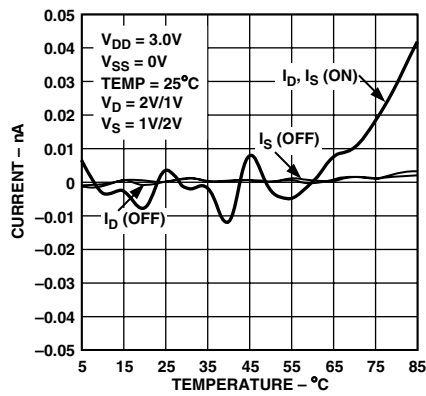

TPC 8. Leakage Current as a Function of Temperature

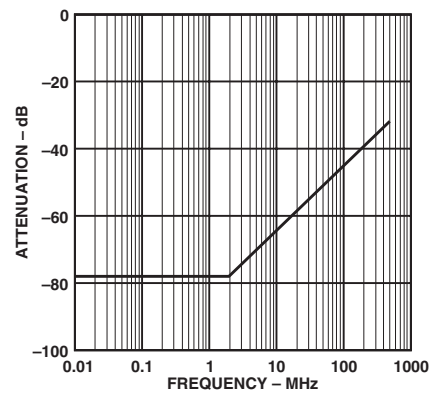

TPC 9. Off Isolation vs. Frequency

# ADG774A

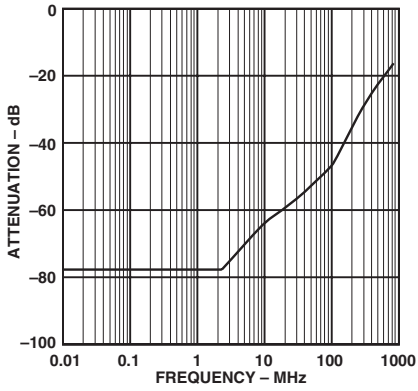

TPC 10. Crosstalk vs. Frequency

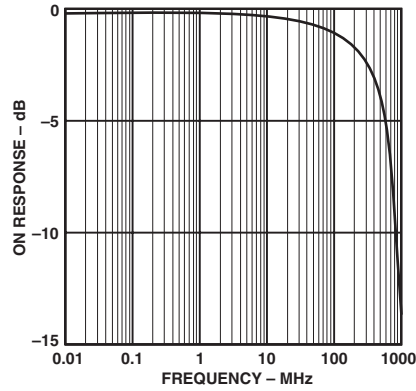

TPC 11. Bandwidth

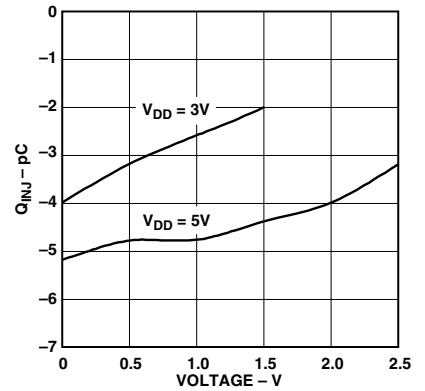

TPC 12. Charge Injection vs. Source Voltage

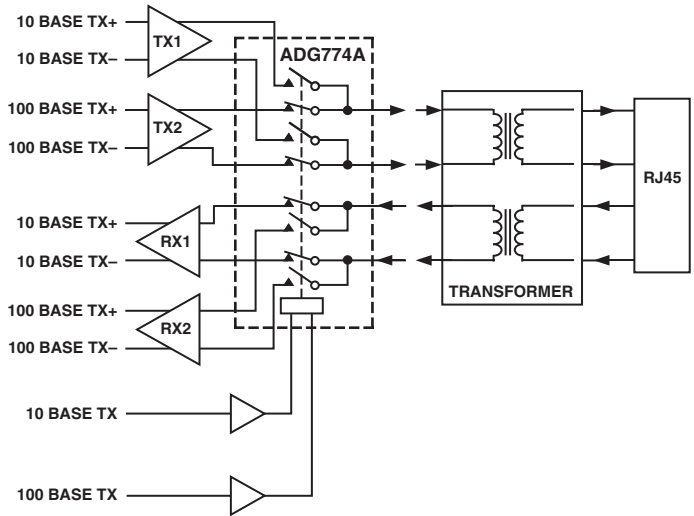

Figure 1. Full Duplex Transceiver

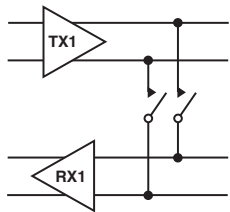

Figure 2. Loop Back

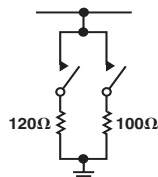

Figure 3. Line Termination

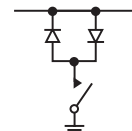
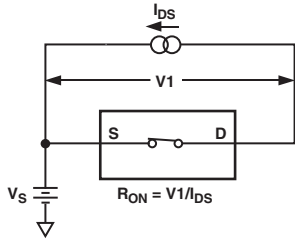
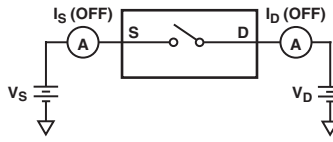

Figure 4. Line Clamp

Test Circuits



Test Circuit 1. On Resistance



Test Circuit 2. Off Leakage

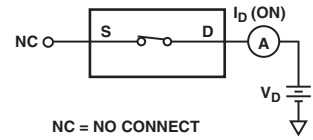

Test Circuit 3. On Leakage

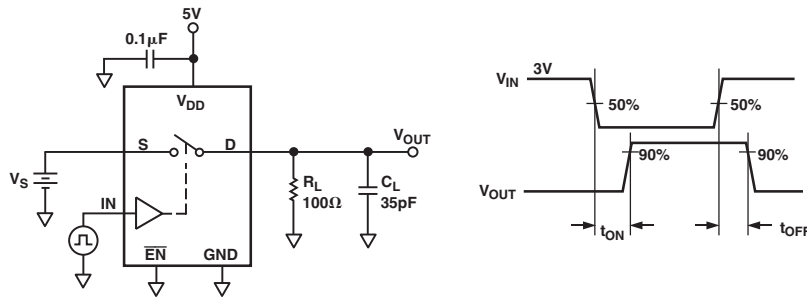

Test Circuit 4. Switching Times

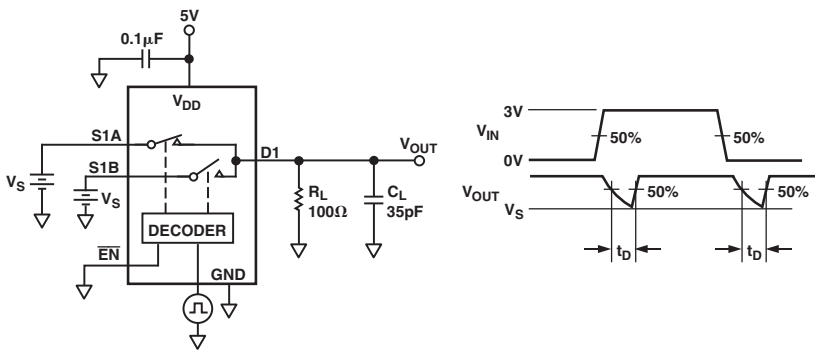

Test Circuit 5. Break-Before-Make Time Delay

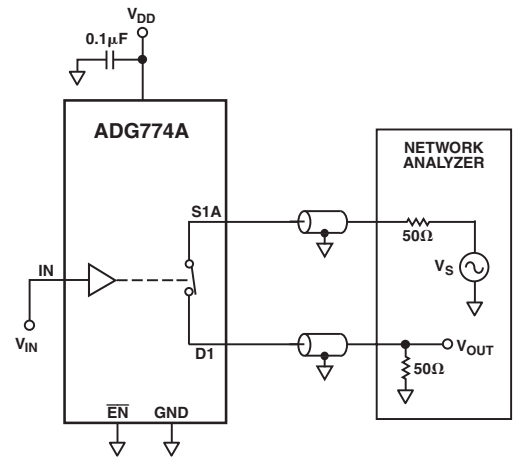

Test Circuit 6. Bandwidth

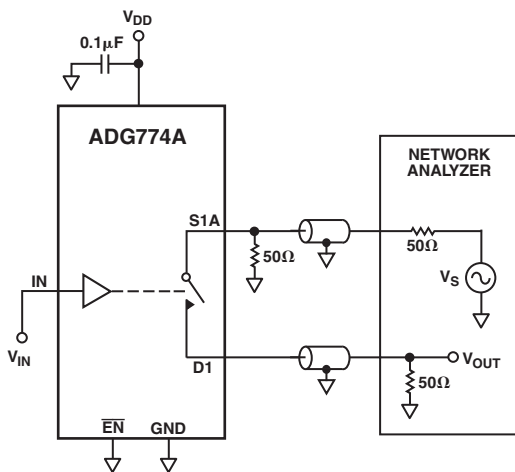

Test Circuit 7. Off Isolation

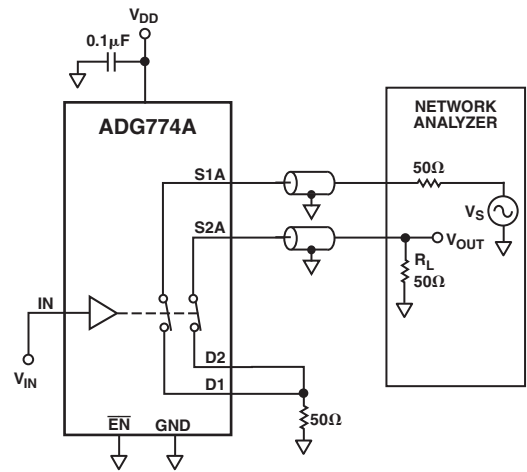

Test Circuit 8. Channel-to-Channel Crosstalk

# ADG774A

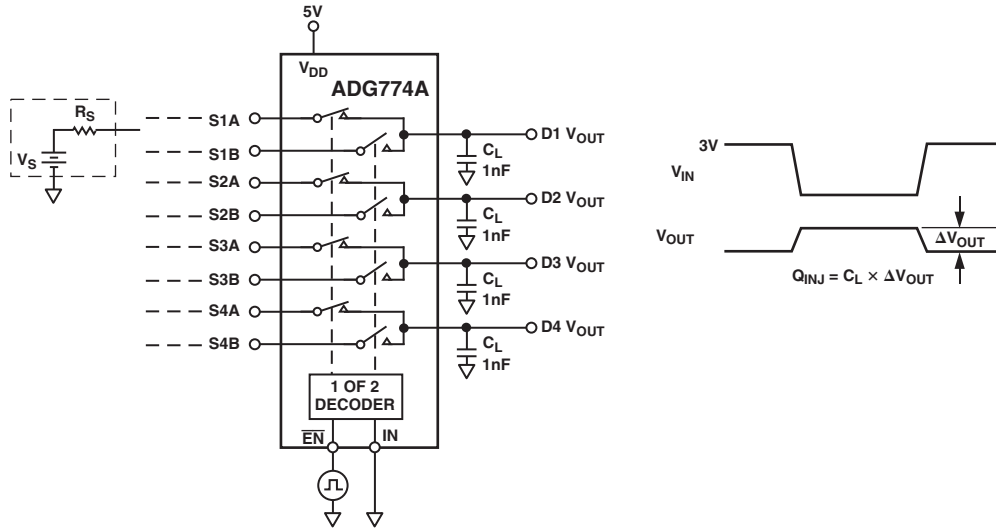

Test Circuit 9. Charge Injection

C02373-0-4/03(A)

## OUTLINE DIMENSIONS

### 16-Lead Shrink Small Outline Package [QSOP] (RQ-16)

Dimensions shown in inches

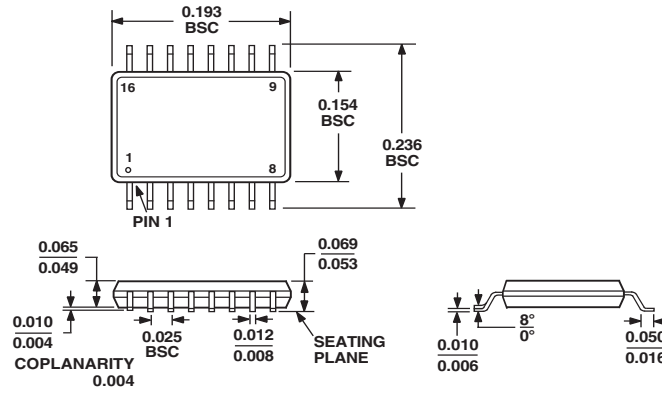

COMPLIANT TO JEDEC STANDARDS MO-137AB

## Revision History

Location	Page
4/03—Data Sheet changed from REV. 0 to REV. A.	
Changes to TPCs 9–11	5
Updated OUTLINE DIMENSIONS	8